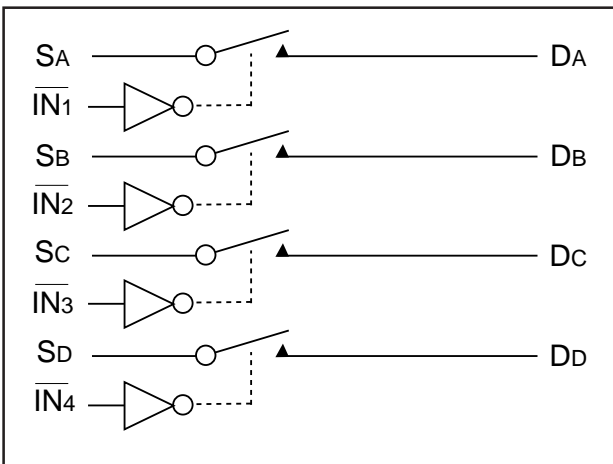

Low ON-Resistance Wideband/Video Quad with Individual Control
Product Features:

- High-performance, low-cost solution to switch between video sources
- Wide bandwidth: 250 MHz
- Low ON-resistance: 3ohm
- Low crosstalk at 10 MHz: -58 dB
- Ultra-low quiescent power (0.1 μ A typical)
- Single supply operation: +5.0V
- Fast switching: 10 ns
- High-current output: 100 mA
- Packages available:
 - 16-pin 150-mil wide plastic QSOP (Q)
 - 16-pin 150-mil wide plastic SOIC (W)
- Functionally equivalent to QS4A101

Truth Table

$\overline{IN1}$	$\overline{IN2}$	$\overline{IN3}$	$\overline{IN4}$	Function
0	X	X	X	SA-DA
X	0	X	X	SB-DB
X	X	0	X	SC-DC
X	X	X	0	SD-DD
1	1	1	1	All Disconnect

Functional Block Diagram

Product Description:

Pericom Semiconductor's PI5V series of mixed signal video circuits are produced in the Company's advanced CMOS low-power technology, achieving industry leading performance.

The PI5V332 is a true bidirectional Quad Video Switch that is recommended for RGB, S-Video, or composite video switching applications. The individual controls allow for video, Hsync, or Vsync enable or disable. The VideoSwitch™ can be driven from a current output RAMDAC or voltage output composite video source.

Low ON-resistance and wide bandwidth make it ideal for video and other applications. Also this device has exceptionally high current capability which is far greater than most analog switches offered today. A single 5V supply is all that is required for operation.

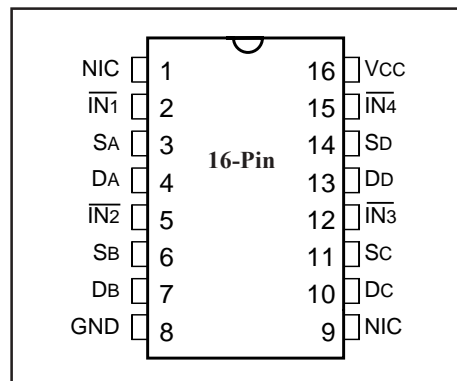
The PI5V332 offers a high-performance, low-cost solution to switch between video sources.

16-Pin Product Configuration

Product Pin Description

Pin Name	Description
SA, SB, SC, SD	Analog Video I/O (Usually Inputs)
$\overline{IN1}$, $\overline{IN2}$, $\overline{IN3}$, $\overline{IN4}$	Select Inputs
DA, DB, DC, DD	Analog Video I/O (Usually Outputs)
GND	Ground
VCC	Power

Maximum Ratings

(Above which the useful life may be impaired. For user guidelines, not tested.)

Storage Temperature	-65°C to +150°C
Ambient Temperature with Power Applied	-40°C to +85°C
Supply Voltage to Ground Potential (Inputs & Vcc Only) ...	-0.5V to +7.0V
Supply Voltage to Ground Potential (Outputs & D/O Only)	-0.5V to +7.0V
DC Input Voltage	-0.5V to +7.0V
DC Output Current	120 mA
Power Dissipation	0.5W

Note:

Stresses greater than those listed under MAXIMUM RATINGS may cause permanent damage to the device. This is a stress rating only and functional operation of the device at these or any other conditions above those indicated in the operational sections of this specification is not implied. Exposure to absolute maximum rating conditions for extended periods may affect reliability.

DC Electrical Characteristics (Over the Operating Range, TA = -40°C to +85°C, VCC = 5V ±5%)

Parameters	Description	Test Conditions ⁽¹⁾	Min.	Typ ⁽²⁾	Max.	Units
V _{ANALOG}	Analog Signal Range		0	—	2.0	V
V _{IH}	Input HIGH Voltage	Guaranteed Logic HIGH Level	2.0	—	—	V
V _{IL}	Input LOW Voltage	Guaranteed Logic LOW Level	-0.5	—	0.8	V
I _{IH}	Input HIGH Current	V _{CC} =Max., V _{IN} =V _{CC}	—	—	±1	µA
I _{IL}	Input LOW Current	V _{CC} =Max., V _{IN} =GND	—	—	±1	µA
I _O	Analog Output Leakage Current	0 ≤ S1, S2 or D ≤ V _{CC} , Switch Off	—	—	±1	µA
V _{IK}	Clamp Diode Voltage	V _{CC} =Min., I _{IN} =-18 mA	—	-0.7	-1.2	V
I _{OS}	Short Circuit Current ⁽³⁾	S1, S2, D=0V V _{CC}	100	—	—	mA
V _H	Input Hysteresis at Control Pins		—	150	—	mV
R _{ON}	Switch On Resistance ⁽⁴⁾ R _L = 75Ω, I _{ON} = 13 mA	V _{CC} =Min., V _{OUT} =0.975V	—	3	7	ohm
		V _{CC} =MIN., V _{OUT} =1.95V	—	7	10	ohm
		R _L = 75Ω, I _{ON} = 26 mA				

Notes:

1. For Max. or Min. conditions, use appropriate value specified under Electrical Characteristics for the applicable device type.
2. Typical values are at V_{CC} = 5.0V, T_A = 25°C ambient and maximum loading.
3. Not more than one output should be shorted at one time. Duration of the test should not exceed one second.
4. Measured by the voltage drop between S1, S2, and D I/O pins at indicated current through the switch. ON resistance is determined by the lower of the voltages on the S1, S2, and D I/O pins. V_{OUT} is the voltage across R_L.

Dynamic Characteristics (Over the Operating Range, $T_A = -40^{\circ}\text{C}$ to $+85^{\circ}\text{C}$, $V_{CC} = 5\text{V} \pm 5\%$)

Parameter	Description	Test Conditions	Min.	Typ.	Max.	Unit
t _{ON}	Turn On Time	R _L = 75ohm, C _L = 20 pF, see Fig. 2	—	2.5	5	ns
t _{OFF}	Turn Off Time	R _L = 75ohm, C _L = 20 pF, see Fig. 2	—	1.1	5	ns
BW ⁽¹⁾	-3 dB Bandwidth	R _L = 150ohm, see Fig. 3	250	—	—	MHz
X _{TALK}	Crosstalk	R _{IN} = 10ohm; R _L = 150ohm, 10 MHz, see Fig. 3	—	-58	—	dB
DG	Differential Gain	R _L = 150ohm, f = 3.58 MHz, see Fig. 1	—	0.64	—	%
DP	Differential Phase	R _L = 150ohm, f = 3.58 MHz, see Fig. 1	—	0.27	—	Deg.
C _{IN} ⁽¹⁾	Input/Enable Capacitance	V _{IN} = 0V, f = 1 MHz	—	—	6	pF
C _{OFF} ⁽¹⁾	Capacitance, Switch Off	V _{IN} = 0V, f = 1 MHz	—	—	6	pF
C _{ON} ⁽¹⁾	Capacitance, Switch On	V _{IN} = 0V, f = 1 MHz	—	—	20	pF
O _{IRR}	Off Isolation	R _L = 150ohm, 10 MHz, see Fig. 3	—	-38	—	dB

Notes:

1. This parameter is determined by device characterization but is not production tested.

Power Supply Characteristics

Parameters	Description	Test Conditions ⁽¹⁾		Min.	Typ ⁽²⁾	Max.	Units
I _{CC}	Quiescent Power Supply Current	V _{CC} = Max.	I _N = GND or V _{CC}	—	0.1	3.0	μA
ΔI _{CC}	Supply Current per Input @ TTL HIGH	V _{CC} = Max.	I _N = 3.4V ⁽³⁾	—	—	2.5	mA
I _{CCD}	Supply Current per Input per MHz ⁽⁴⁾	V _{CC} = Max., S1, S2, and D Pins Open $\overline{\text{EN}}$ = GND Control Input Toggling 50% Duty Cycle		—	—	0.25	mA/ MHz

Notes:

1. For Max. or Min. conditions, use appropriate value specified under Electrical Characteristics for the applicable device.
2. Typical values are at V_{CC} = 5.0V, +25°C ambient.
3. Per TTL driven input (V_{IN} = 3.4V, control inputs only); S1, S2, and D pins do not contribute to I_{CC}.
4. This current applies to the control inputs only and represent the current required to switch internal capacitance at the specified frequency. The S1, S2, and D I/O pins generate no significant AC or DC currents as they transition. This parameter is not tested, but is guaranteed by design.

Definitions

Symbol	Description
RON	Resistance between source and drain with switch in the ON state.
IO	Output leakage current measured at S1, S2, and D with the switch OFF.
VIN	Digital voltage at the IN pin that selects between S1 and S2 analog inputs.
VEN	A voltage that ENABLES the chip.
CIN	Capacitance at the digital inputs.
COFF	Capacitance at analog I/O (S1, S2, D) with switch OFF.
CON	Capacitance at analog I/O (S1, S2, D) with switch ON.
VIH	Minimum input voltage for logic HIGH.
VIL	Minimum input voltage for logic LOW.
I _{IH} (I _{IL})	Input current of the digital input.
I _{OS}	Minimum short circuit current for S1, S2 and D.
ton	Propagation delay measured between 50% of the digital input to 90% of the analog output when switch is turned ON. The peak analog voltage is 0.714V.
toff	Propagation delay measured between 50% of the digital input to 90% of the analog output when switch is turned OFF. The peak analog voltage is 0.714V.
BW	Frequency response of the switch in the ON state measured at 3dB down.
XTALK	Is an unwanted signal coupled from channel to channel. Measured in -dB. $X_{TALK} = 20 \text{ LOG } V_{OUT}/V_{IN}$. This is non-adjacent crosstalk.
DG	Differential gain is the difference measurement between two bias levels, for instance analog input signals of 0V to 0.714V.
DP	Differential phase is the difference measurement between two bias levels, for instance analog input signals of 0V to 0.714V.
OIRR	Off isolation is the resistance (measured in -dB) between the input and output with the switch off (NO).

Test Circuits

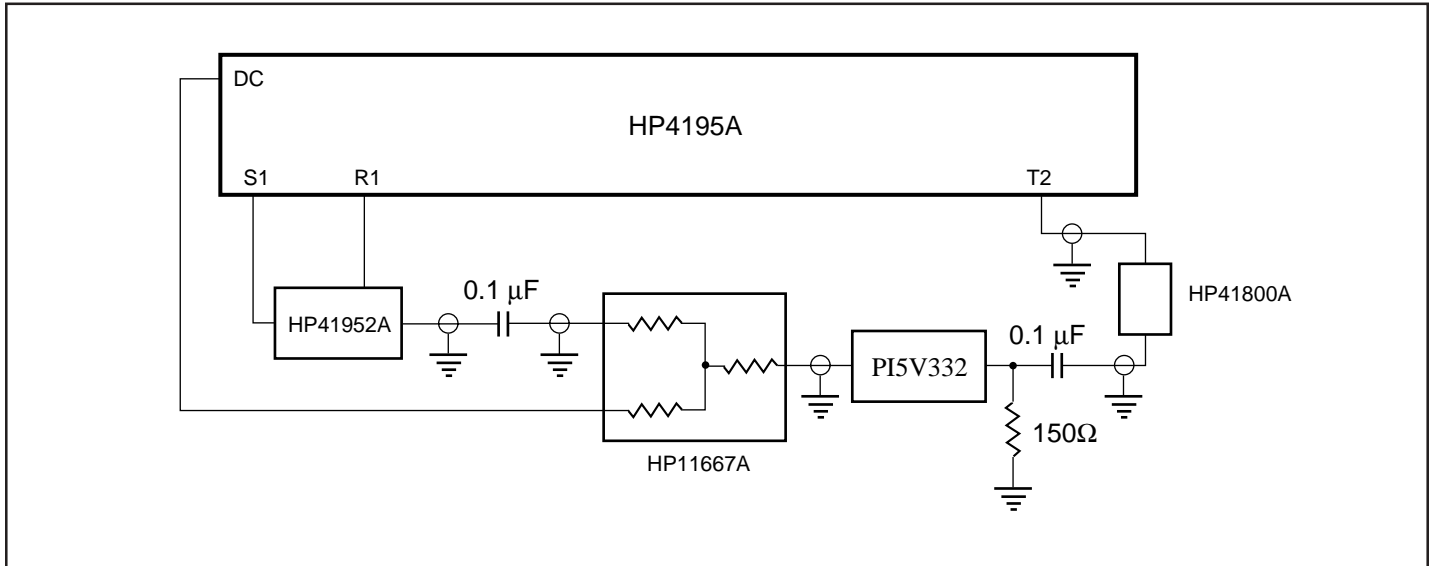

Figure 1. Differential Gain/Phase

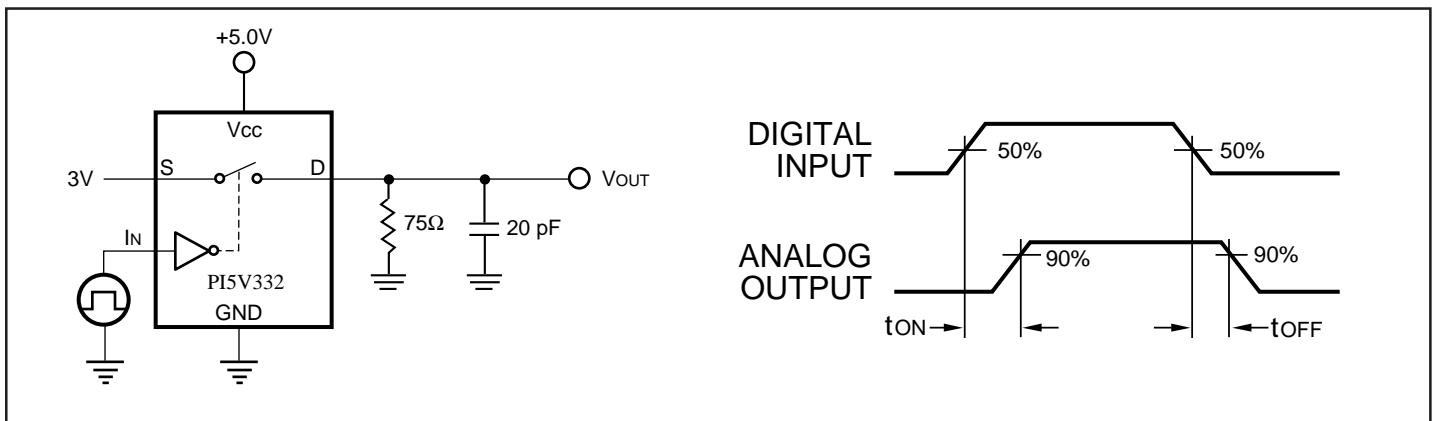

Figure 2. Switching Time

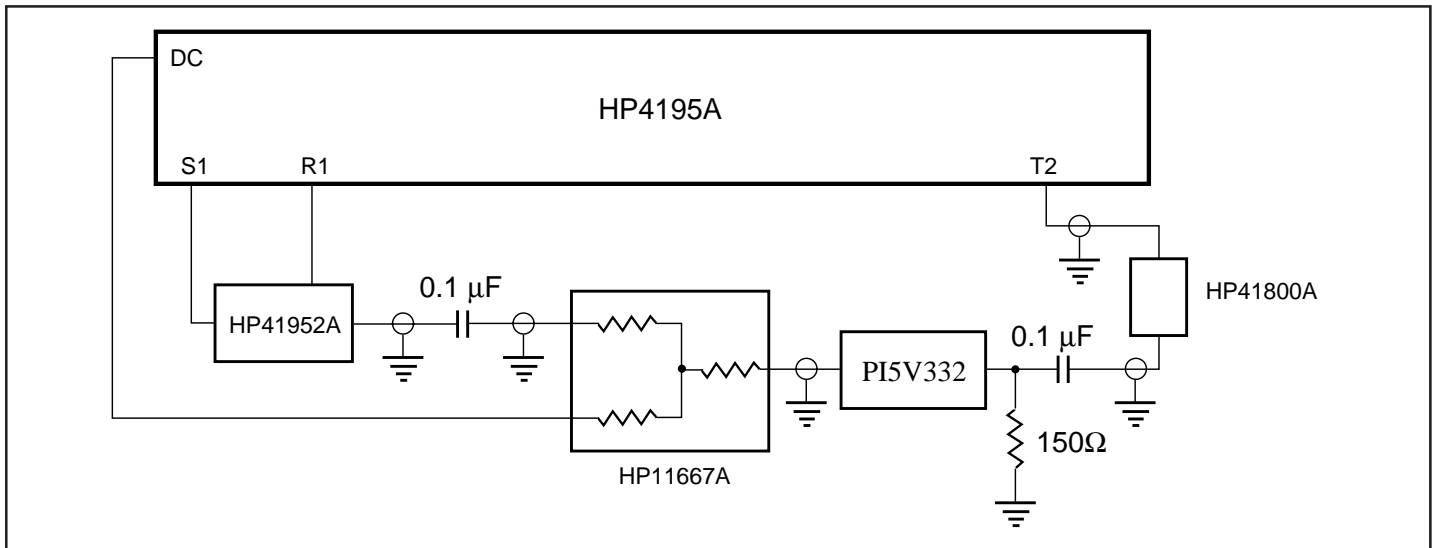
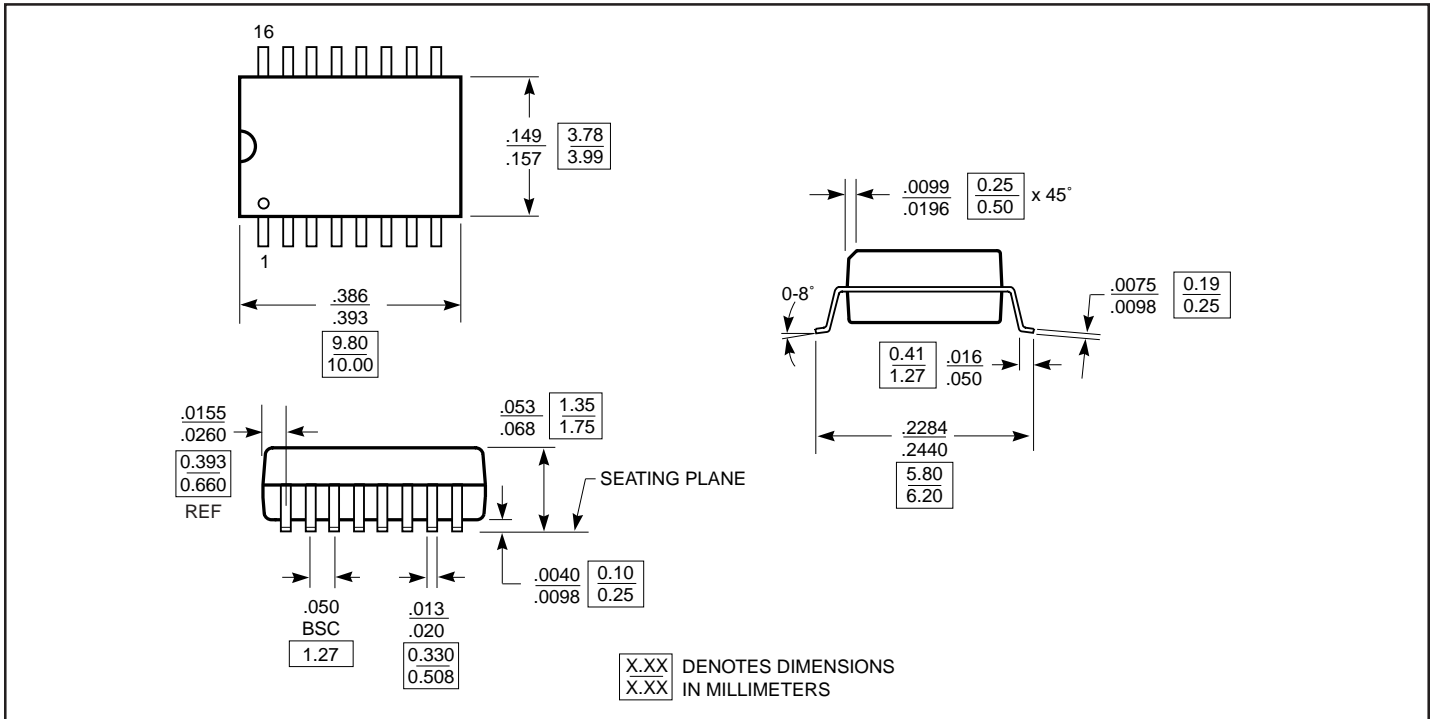
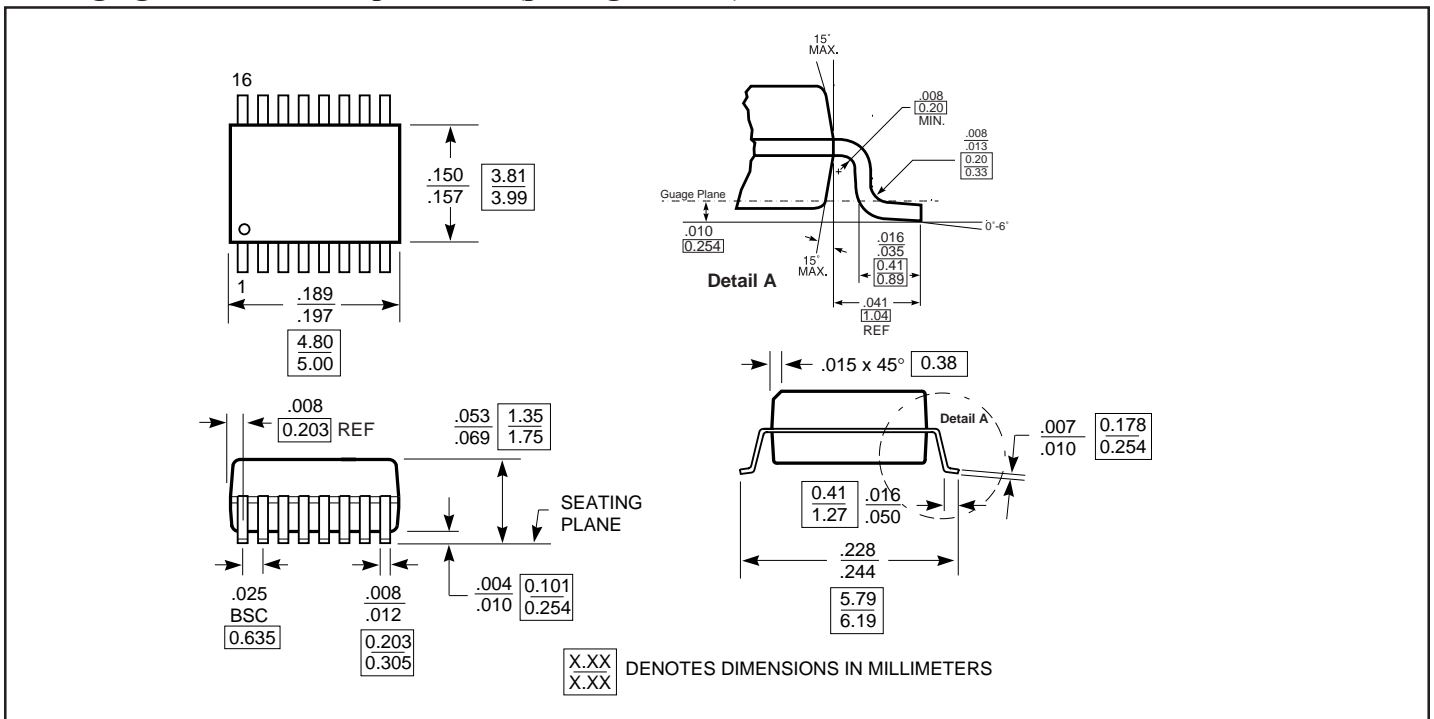

Figure 3. Gain/Phase, Crosstalk, Off-Isolation

Packaging Mechanical: 16-pin SOIC (package code W)



Packaging Mechanical: 16-pin QSOP (package code Q)



Ordering Information

Part Number	Package Information
PI5V332W	16-pin SOIC (W)
PI5V332Q	16-pin QSOP (Q)

Pericom Semiconductor Corporation

2380 Bering Drive • San Jose, CA 95131 • 1-800-435-2336 • Fax (408) 435-1100 • <http://www.pericom.com>